

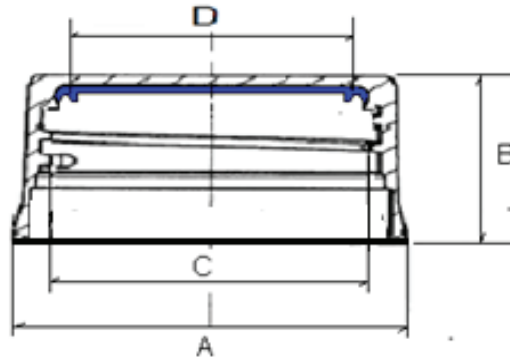

# 106391

28mm PCO (1881) White PP Tamper Evident Closure with EVA Liner

K.G. International - sales@kgint.com - +1 305 499-9816



| VARIABLE DE CALIDAD / QUALITY VARIABLE                       | *PRC | UM /MEASURE UNIT | ESPECIFICACIONES/ESPECIFICATIONS |                  |                 |
|--------------------------------------------------------------|------|------------------|----------------------------------|------------------|-----------------|
|                                                              |      |                  | MÍNIMO/MINI MUM                  | ESTÁNDAR/T ARGET | MÁXIMO/MAXI MUM |
| Diámetro Externo/ Outside Diameter(A)                        | 1    | mm               | 31.10                            | 31.40            | 31.70           |
| Altura / Height (B)                                          | 1    | mm               | 16.30                            | 16.60            | 16.90           |
| Diámetro Interno / Inside Diameter (C)                       | 1    | mm               | 25.55                            | 25.70            | 25.85           |
| Diámetro Block / Block Diameter ( D )                        | 1    | mm               | 25.10                            | 25.20            | 25.30           |
| Peso del liner / liner weigth                                | 1    | mm               | 0.20                             | 0.23             | 0.26            |
| Peso de tapa sin liner / cap without liner weigth            | 1    | g                | 2.40                             | 2.50             | 2.60            |
| Peso de tapa con liner / Cap with liner weigth               | 1    | g                | 2.60                             | 2.73             | 2.86            |
| Espesor del fondo sin liner / bottom thickness without liner | 1    | mm               | 1.40                             | 1.50             | 1.60            |
| Espesor del fondo con liner / bottom thickness with liner    | 1    | mm               | 1.55                             | 1.70             | 1.85            |
| Planaridad / Flatness                                        | 1    | mm               | -30.00                           | 0.00             | 20.00           |
| Ruptura de puente / Bridge Breaking                          | 1    | lb/pulg          | 4                                | 8                | 12              |
| Fuga Dinámica / Dynamic Leaking                              | 1    | psi/1 min.       | 150                              | 165              | 180             |
| Torque de cierre estático / Static torque                    | 1    | lb/pulg          | 18                               | 20               | 22              |
| Torque de apertura inmediato / Initial removal torque        | 1    | lb/pulg          | 9                                | 14               | 20              |
| Impacto de bala / Bullet impact                              | 1    | n/a              | pasa/no pasa                     |                  |                 |
| Rigidéz / rigidity                                           | 2    | n/a              | pasa/no pasa                     |                  |                 |
| Adhesividad / adhesiveness                                   | 2    | n/a              | pasa/no pasa                     |                  |                 |
| Hidrostática / Hydrostatics                                  | 2    | n/a              | pasa/no pasa                     |                  |                 |
| Visual centro / Visual center                                | 2    | n/a              | pasa/no pasa                     |                  |                 |
| Visual color / Visual color                                  | 2    | n/a              | pasa/no pasa                     |                  |                 |